

PARTS CATALOGUE



T3BMS (6L56)

T3.5BMS (6L56)

SEATAN
GENUINE
Parts & Accessories

FOREWORD

This Parts Catalogue is related to the parts for the model(s) on the cover page. When you are ordering replacement parts, please refer to this Parts Catalogue and quote both part numbers and part names correctly.

1. Modifications or additions which have been made after the issue of the Parts Catalogue will be announced in the Parts News.
It is advisable that you make the necessary corrections to the Parts Catalogue according to the Parts News.

2. Abbreviations

The following abbreviations are used in this Parts Catalogue.

“UR” Use specified parts number.

“UN” Use as many as needed.

“AP” Alternate Parts

“LM” Locally Made (Parts need to be ordered locally)

“F#” Frame No. (Applicable machine No.)

“O/S” Over Size

3. The number of components for assembly

- Parts, which are to be supplied in an assembly, are listed with a dot (.) in front of the part name as shown below.
- The numeral appearing to the right of each component part indicates the quantity of parts for each assembly unit.

PART NO.	DESCRIPTION	Q'TY	REMARKS
2F5-83310-60	FRONT FLASHER LIGHT ASSY	2	
115-83311-60	.BULB (6V-18W)	1	

4. Applicable colours of graphics are represented in the “REMARKS” as shown below.

PART NO.	DESCRIPTION	Q'TY	REMARKS
2N4-24110-00-X5	FUEL TANK COMP.	2	MXR
3J1-24240-10	.GRAPHIC, FUEL TANK	1	FOR MXR

5. Note that the illustrations for reference in finding parts numbers are not to be used for assembling. When assembling, please use the applicable service manual.

6. The asterisk (*) before a reference number indicates modified items after the first edition.

7. Applicable Serial No.

Engine Serial No.

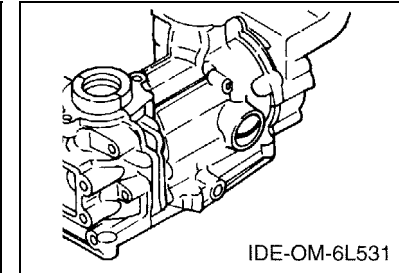
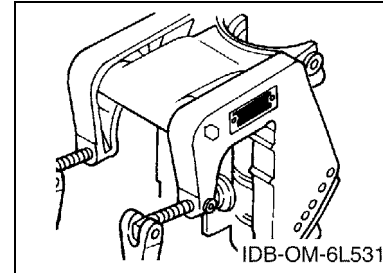

8. Applicable Engine Starting Serial No.

Model	Serial No.	Model	Serial No.
3A	6L5K-1011781		

9. Applicable Colour Code

Abbreviation	Colour Name	Colour Code
DBNM2	DARK BLUISH GRAY METALLIC 2	004D

10. Quantity Column Information

Column No.	Name Of Q'ty Column	Applicable Model
1	6L56	3AMH

CONTENTS

COWLING & FUEL	1
CYLINDER & CRANKCASE	3
INTAKE	5
STARTER	7
GENERATOR	8
ELECTRICAL	9
CONTROL	10
UPPER CASING & BRACKET	12
LOWER CASING & DRIVE	15
REPAIR KIT	18
INDEX	
NUMERICAL INDEX	20

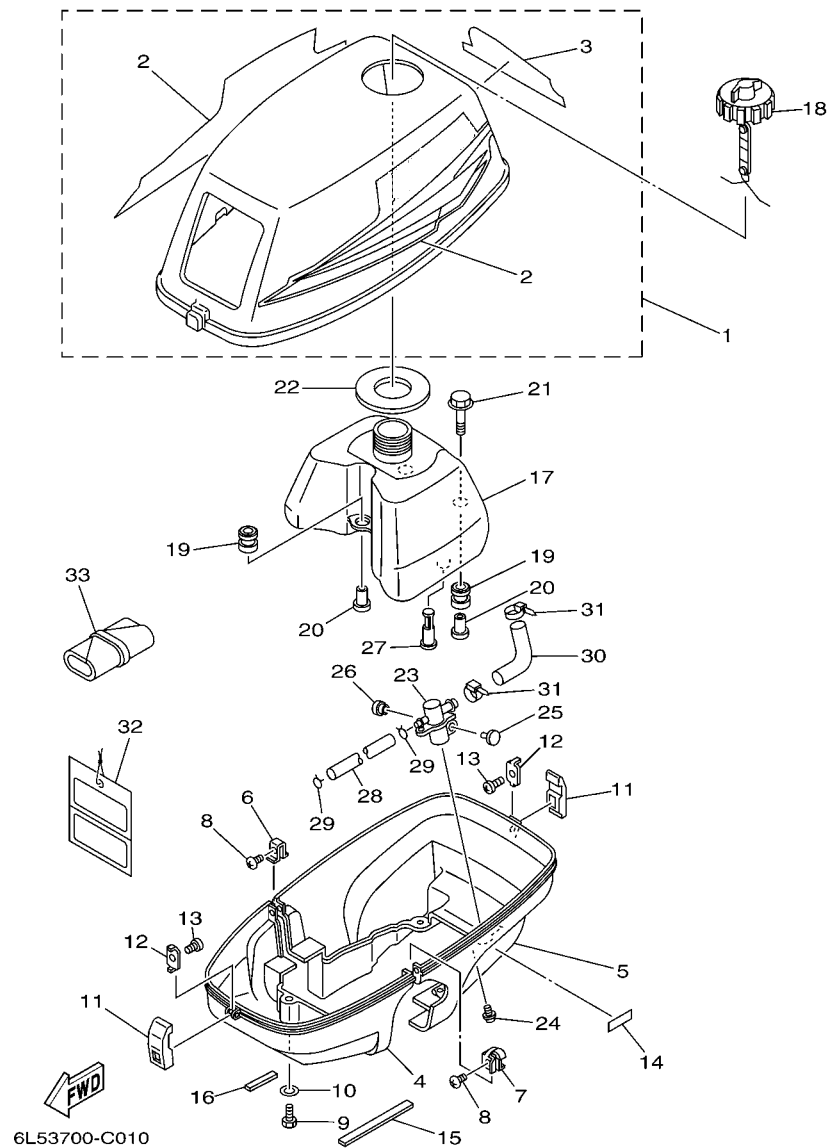
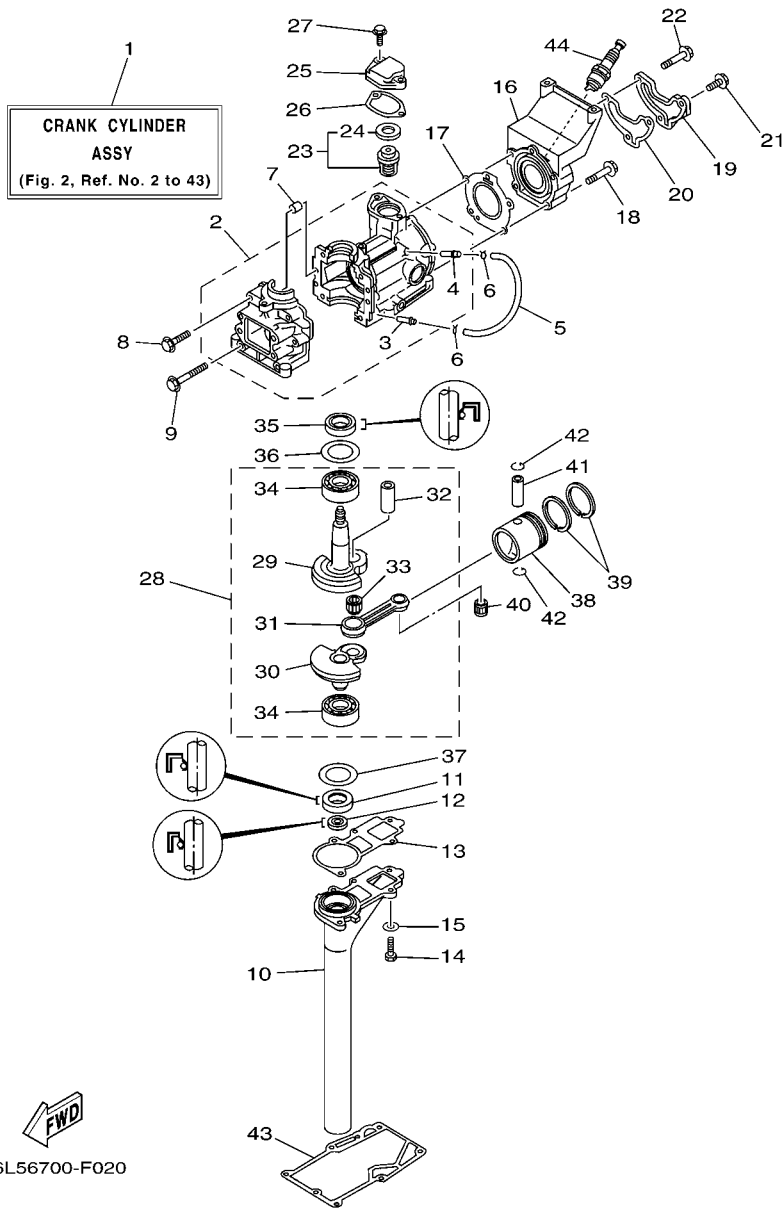

FIG. 1 COWLING & FUEL

REF. NO.	PART NO.	DESCRIPTION	6L56				REMARKS
1	6L5-42610-13-4D	TOP COWLING ASSY	1				
2	6L5-W0070-13	.GRAPHIC SET	1				
3	6L5-42678-12	.GRAPHIC, REAR	1				
4	6L5-42711-11	COWLING, BOTTOM 1	1				
5	6L5-42712-12	COWLING, BOTTOM 2	1				
6	6L5-42774-00	STAY, APRON 1	1				
7	6L5-42775-00	STAY, APRON 2	1				
8	97880-05010	SCREW, PAN HEAD	2				
9	97095-06016	BOLT	4				
10	92995-06600	WASHER	4				
11	6L5-42647-00	HOLDER, CLAMP BAND	2				
12	6L5-42823-00	PLATE, STOP	2				
13	90167-03M02	SCREW, TAPPING	2				
14	6L5-24591-00	EMBLEM, FUEL COCK	1				
15	6L5-42662-00	DAMPER	1				
16	6L5-42663-00	DAMPER	1				
17	6L5-24111-02	TANK, FUEL	1				
18	6L5-24610-00	CAP ASSY	1				
19	6A0-82317-00	DAMPER, IGNITION COIL	3				
20	90387-06119	COLLAR	3				
21	90119-06M65	BOLT, WITH WASHER	2				
22	6L5-24641-00	GASKET, CAP 1	1				
23	6L5-24500-60	FUEL COCK ASSY 1	1				
24	90159-06M10	SCREW, WITH WASHER	1				
25	6L5-44196-00	INDICATOR 3	1				
26	6L5-44197-00	INDICATOR 4	1				
27	6L5-24251-00	STRAINER 1	1				



6L56700-F020

FIG. 2 CYLINDER & CRANKCASE

REF. NO.	PART NO.	DESCRIPTION	6L56				REMARKS
1	6L5-W0090-01-1S	CRANK CYLINDER ASSY	1				
2	6L5-15100-01-1S	CRANKCASE ASSY	1				
3	624-14485-00	.PIPE, JOINT	1				
4	6E5-11372-01	.NIPPLE, HOSE	1				
5	90445-07M29	HOSE (L135)	1				
6	90467-06016	CLIP	2				
7	93606-12019	PIN, DOWEL	2				
8	90105-06M16	BOLT, FLANGE	4				
9	90105-06M40	BOLT, FLANGE	2				
10	6L5-15396-00-94	HOUSING, OIL SEAL	1				
11	93101-20M29	OIL SEAL	1				
12	93101-09M42	OIL SEAL	1				
13	6L5-15369-A0	GASKET, OIL SEAL HOUSING	1				
14	97095-06020	BOLT	5				
15	92995-06600	WASHER	5				
16	6L5-11111-00-1S	HEAD, CYLINDER 1	1				
17	6L5-11181-A2	GASKET, CYLINDER HEAD 1	1				
18	90119-06047	BOLT, WITH WASHER	3				
19	6L5-11191-00-1S	COVER, CYLINDER HEAD 1	1				
20	6L5-11193-A1	GASKET, HEAD COVER 1	1				
21	90119-06MA2	BOLT, WITH WASHER	1				
22	90119-06027	BOLT, WITH WASHER	2				
23	6E5-12411-02	THERMOSTAT	1				
24	6E5-12412-00	.SEAL, THERMOSTAT	1				
25	6L5-12413-00-1S	COVER, THERMOSTAT	1				
26	6L5-12414-A1	GASKET, COVER	1				
27	90119-06MA2	BOLT, WITH WASHER	2				

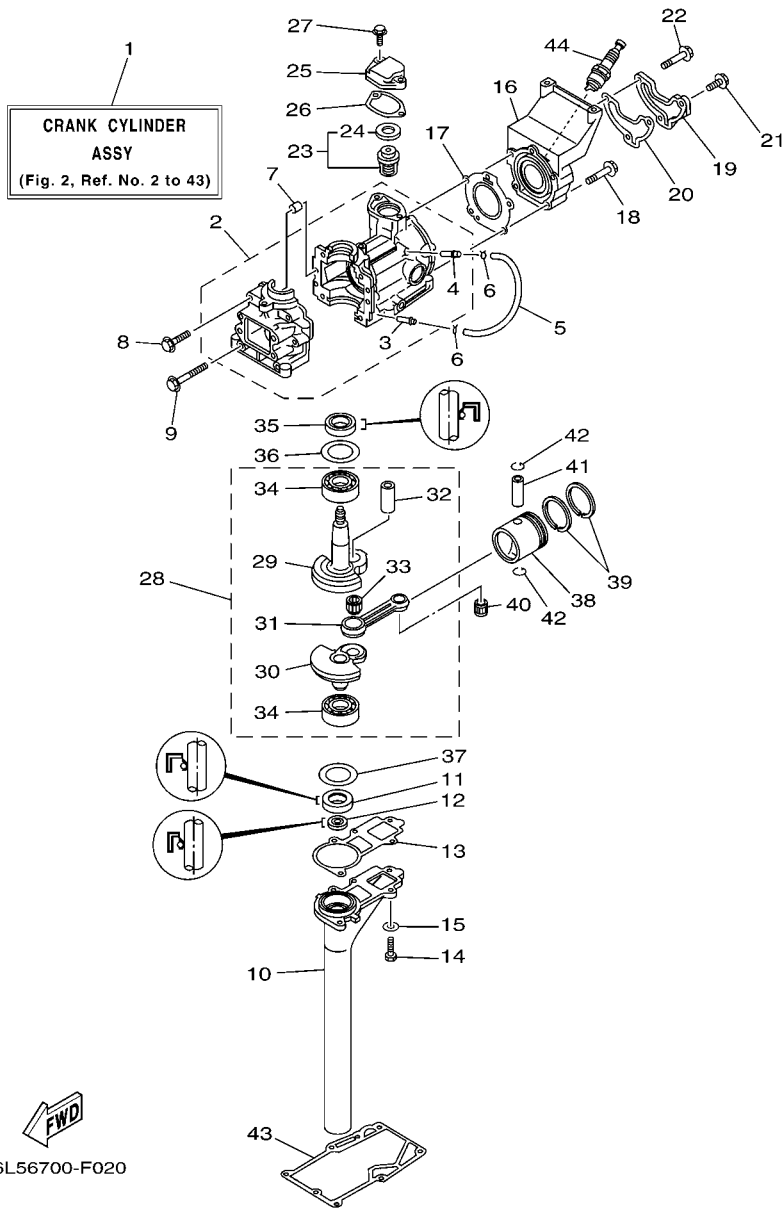

6L56700-F020

FIG. 2 CYLINDER & CRANKCASE

REF. NO.	PART NO.	DESCRIPTION	6L56				REMARKS
28	6L5-11400-00	CRANKSHAFT ASSY	1				
29	6L5-11412-00	.CRANK 1	1				
30	6L5-11422-00	.CRANK 2	1				
31	6L5-11651-00	.ROD, CONNECTING	1				
32	6L5-11681-00	.PIN, CRANK 1	1				
33	93310-416N7	.BEARING	1				
34	93306-204U0	.BEARING	2				
35	93102-20M06	OIL SEAL	1				
36	90201-32M00	WASHER, PLATE	1				
37	90201-32M01	WASHER, PLATE	1				
38	6L5-11631-00-96	PISTON (STD)	1				
	6L5-11635-00	PISTON (0.25MM O/S)	1				AP
	6L5-11636-00	PISTON (0.50MM O/S)	1				AP
39	6L5-11610-00	PISTON RING SET (STD)	1				
	6L5-11610-10	PISTON RING SET (0.25MM O/S)	1				AP
	6L5-11610-20	PISTON RING SET (0.50MM O/S)	1				AP
40	93310-112U0	BEARING	1				
41	6L5-11633-00	PIN, PISTON	1				
42	93450-13022	CIRCLIP	2				
43	6L5-45113-A1	GASKET, UPPER CASING	1				
44	94702-00274	PLUG, SPARK (NGK BR6HS-10)	1				

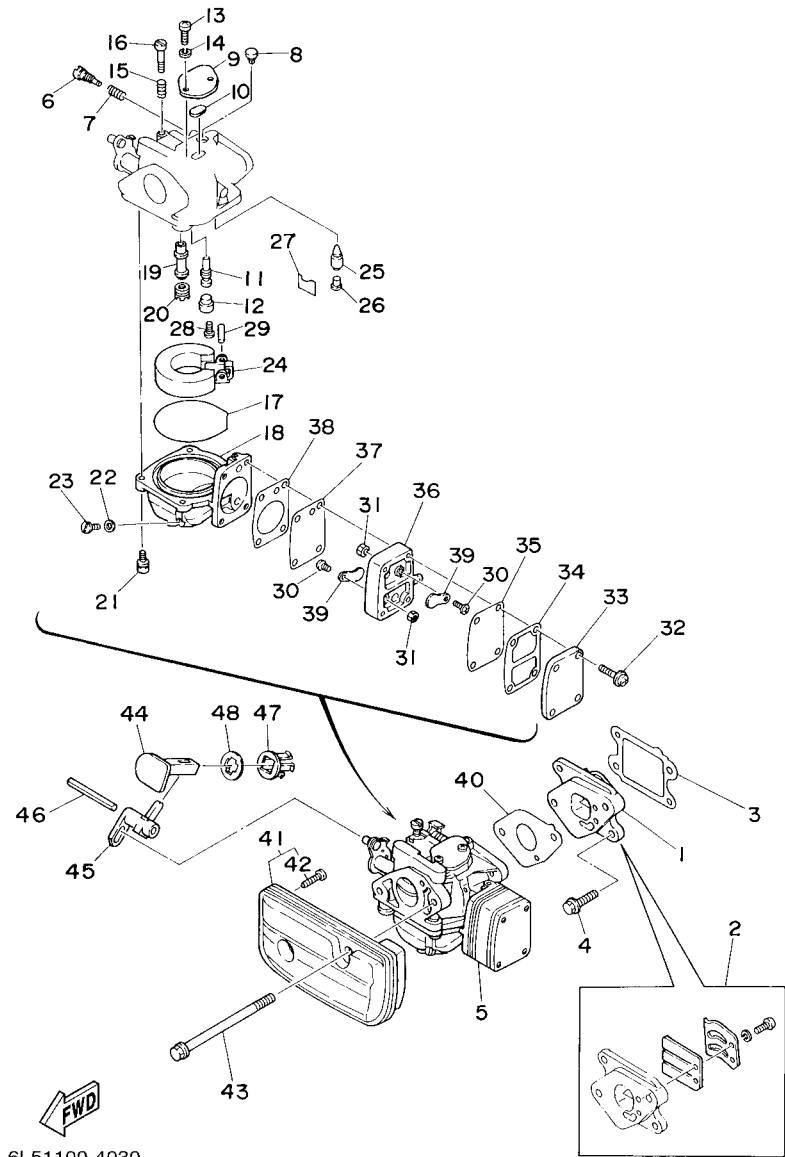

6L51100-4030

FIG. 3 INTAKE

REF. NO.	PART NO.	DESCRIPTION	6L56				REMARKS
1	6L5-13610-02	REED VALVE ASSY	1				
2	6L5-W0004-02	.REED SET	1				
3	6L5-13621-A2	GASKET, VALVE SEAT	1				
4	95895-06016	BOLT, FLANGE	2				
5	6L5-14301-03	CARBURETOR ASSY 1	1				
6	679-14923-00	.SCREW, PILOT	1				
7	679-14555-00	.SPRING	1				
8	6G1-14966-00	.CAP	1				
9	6G1-14527-00	.PLATE	1				
10	6G1-14126-00	.GASKET	1				
11	6L5-14948-03	.JET (#40)	1				
12	676-14966-00	.CAP	1				
13	97880-04010	.SCREW, PAN HEAD	2				
14	92990-04100	.WASHER, SPRING	2				
15	90501-10326	.SPRING, COMPRESSION	1				
16	63V-14523-00	.SCREW, STOP	1				
17	6G1-14984-00	.O-RING	1				
18	6G1-14980-01	.BODY, FLOAT CHAMBER	1				
19	6L5-14947-01	.JET, NEEDLE	1				
20	676-14943-14	.JET, MAIN (#68)	1				
21	97980-04114	.SCREW, WITH WASHER	4				
22	6G1-14398-00	.WASHER	1				
23	6G1-14992-00	.SCREW, DRAIN	1				
24	6G1-14985-00	.FLOAT	1				
25	6G1-14546-00	.VALVE, NEEDLE	1				
26	676-14186-00	.PIN, FLOAT	1				
27	663-14159-00	.CLIP	1				

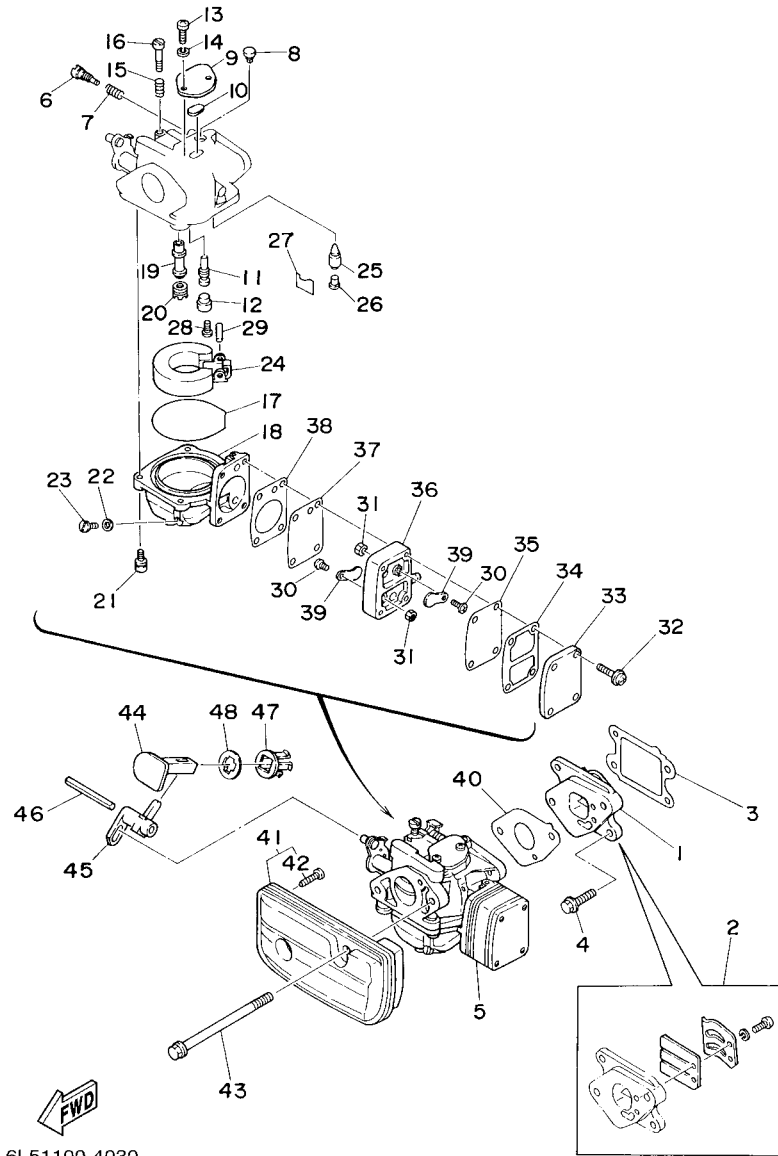

6L51100-4030

FIG. 3 INTAKE

REF. NO.	PART NO.	DESCRIPTION	6L56				REMARKS
28	98580-04008	.SCREW, PAN HEAD	1				
29	688-14548-00	.PIN, FLOAT ARM	1				
30	98980-03006	.SCREW, BIND	2				
31	95380-03600	.NUT	2				
32	97980-04125	.SCREW, WITH WASHER	4				
33	6G1-24452-00	.COVER	1				
34	6G1-24432-00	.GASKET, FUEL PUMP 2	1				
35	6G1-24471-00	.DIAPHRAGM	1				
36	6G1-24412-01	.BODY 1	1				
37	6G1-24411-00	.DIAPHRAGM	1				
38	6G1-24431-01	.GASKET, FUEL PUMP 1	1				
39	6L5-24421-00	.VALVE, CHECK	2				
40	6L5-14198-A1	GASKET	1				
41	6L5-14440-00	SILENCER ASSY, INTAKE	1				
42	97780-40716	.SCREW, TAPPING	2				
43	95895-06095	BOLT, FLANGE	2				
44	6L5-41271-00	KNOB, CHOKE	1				
45	6L5-41252-00	LEVER, CHOKE 1	1				
46	91690-40048	PIN, SPRING	1				
47	689-41273-00	GROMMET	1				
48	6J8-41274-00	GROMMET 2	1				

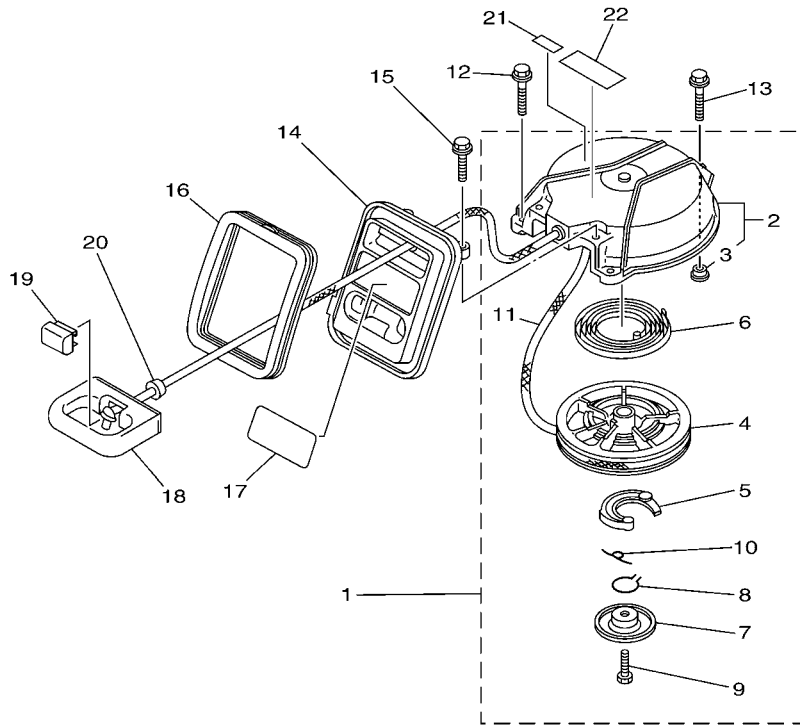

6L53700-C040

*1: CUT FROM 50M ROLLS, PART NO.90790-77002, CUTTING LENGTH 1.65M

FIG. 4 STARTER

REF. NO.	PART NO.	DESCRIPTION	6L56				REMARKS
1	6L5-15710-00	STARTER ASSY	1				
2	6L5-15711-00	.CASE, STARTER	1				
3	90387-06M70	..COLLAR	1				
4	6L5-15714-00	.DRUM, SHEAVE	1				
5	6L5-15741-00	.PAWL, DRIVE	1				
6	6L5-15713-00	.SPRING, STARTER	1				
7	6L5-15716-00	.PLATE, DRIVE	1				
8	6A1-15705-00	.SPRING, DRIVE PAWL	1				
9	97313-06012	.BOLT	1				
10	6A1-15767-00	.SPRING	1				
11	*	.WIRE (L:1650MM)	1				*1
12	95895-06020	BOLT, FLANGE	2				
13	95895-06035	BOLT, FLANGE	1				
14	6L5-15758-00-98	GUIDE, ROPE	1				
15	95895-06016	BOLT, FLANGE	2				
16	6L5-15761-00	SEAL, RUBBER 1	1				
17	6L5-42677-10	GRAPHIC, FRONT	1				
18	6L5-15755-00	HANDLE, STARTER	1				
19	6L5-15779-00	COVER	1				
20	6L5-15789-00	DAMPER	1				
21	6H8-42791-10	MARK 1	1				
22	6A1-83625-41	MARK 5	1				

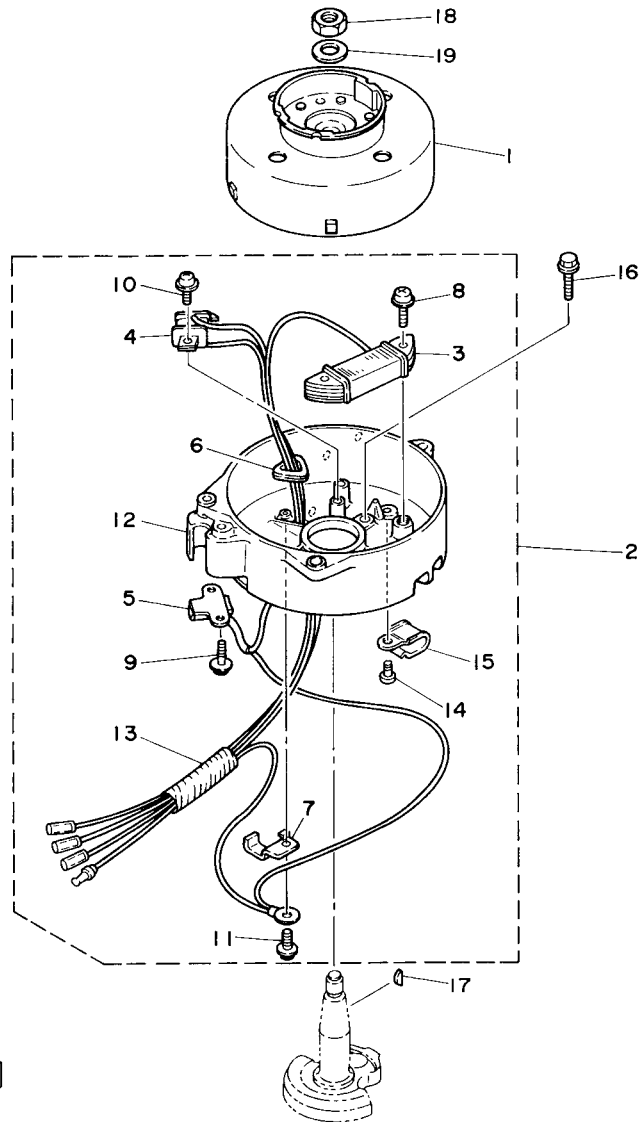

6L51100-4050

FIG. 5 GENERATOR

REF. NO.	PART NO.	DESCRIPTION	6L56				REMARKS
1	6L5-85550-M1	ROTOR ASSY	1				
2	6L5-85560-M1	BASE ASSY	1				
3	6E0-85520-70	.COIL, CHARGE	1				
4	6L5-85595-M0	.COIL, PULSER	1				
5	6L5-85592-M0	.PULSER COIL ASSY	1				
6	6E0-81336-70	.GROMMET	1				
7	6E0-81328-70	.CLAMP	1				
8	90159-05038	.SCREW, WITH WASHER	2				
9	90159-05037	.SCREW, WITH WASHER	2				
10	90159-04036	.SCREW, WITH WASHER	2				
11	90159-04035	.SCREW, WITH WASHER	1				
12	6L5-15771-01-94	.STAY 1	1				
13	90446-10M01	.HOSE (L60)	1				
14	97803-05008	.SCREW, PAN HEAD	1				
15	90465-10M34	.CLAMP	1				
16	95895-06016	BOLT, FLANGE	2				
17	90280-04M06	KEY, WOODRUFF	1				
18	90170-10113	NUT	1				
19	90201-10126	WASHER, PLATE	1				

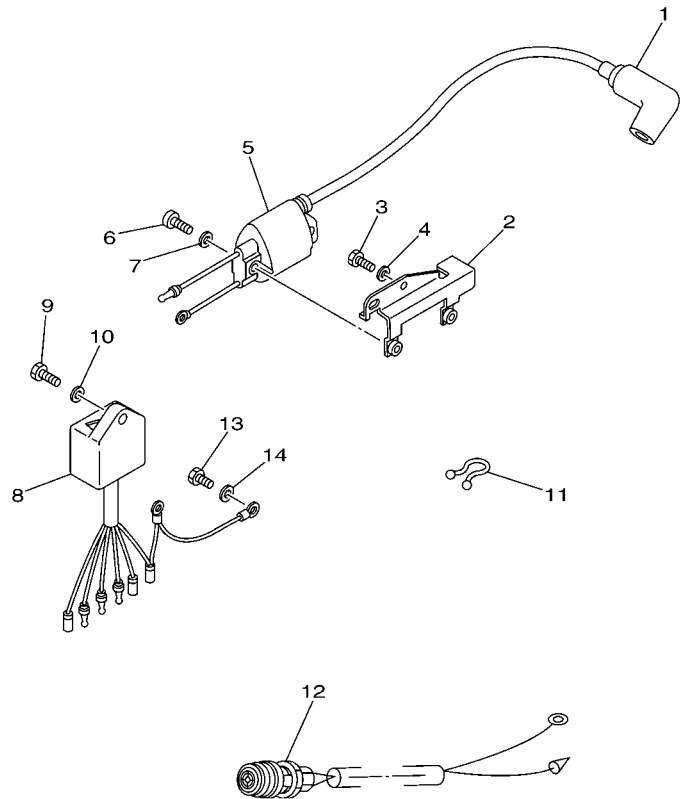

FWD
6L53700-C060

FIG. 6 ELECTRICAL

REF. NO.	PART NO.	DESCRIPTION	6L56				REMARKS
1	6G1-82370-21	PLUG CAP ASSY	1				
2	6L5-82316-00	BRACKET, IGNITION COIL	1				
3	97095-06016	BOLT	2				
4	92995-06600	WASHER	2				
5	6L5-85570-N0	IGNITION COIL ASSY	1				
6	97880-06016	SCREW, PAN HEAD	2				
7	92990-06600	WASHER, PLATE	2				
8	6L5-85540-M0	C.D.I. UNIT ASSY	1				
9	97095-06016	BOLT	1				
10	92995-06600	WASHER	1				
11	90465-18147	CLAMP	1				
12	6L5-82550-00	ENGINE STOP SWITCH ASSY	1				
13	97090-06012	BOLT	1				
14	92990-06600	WASHER, PLATE	1				

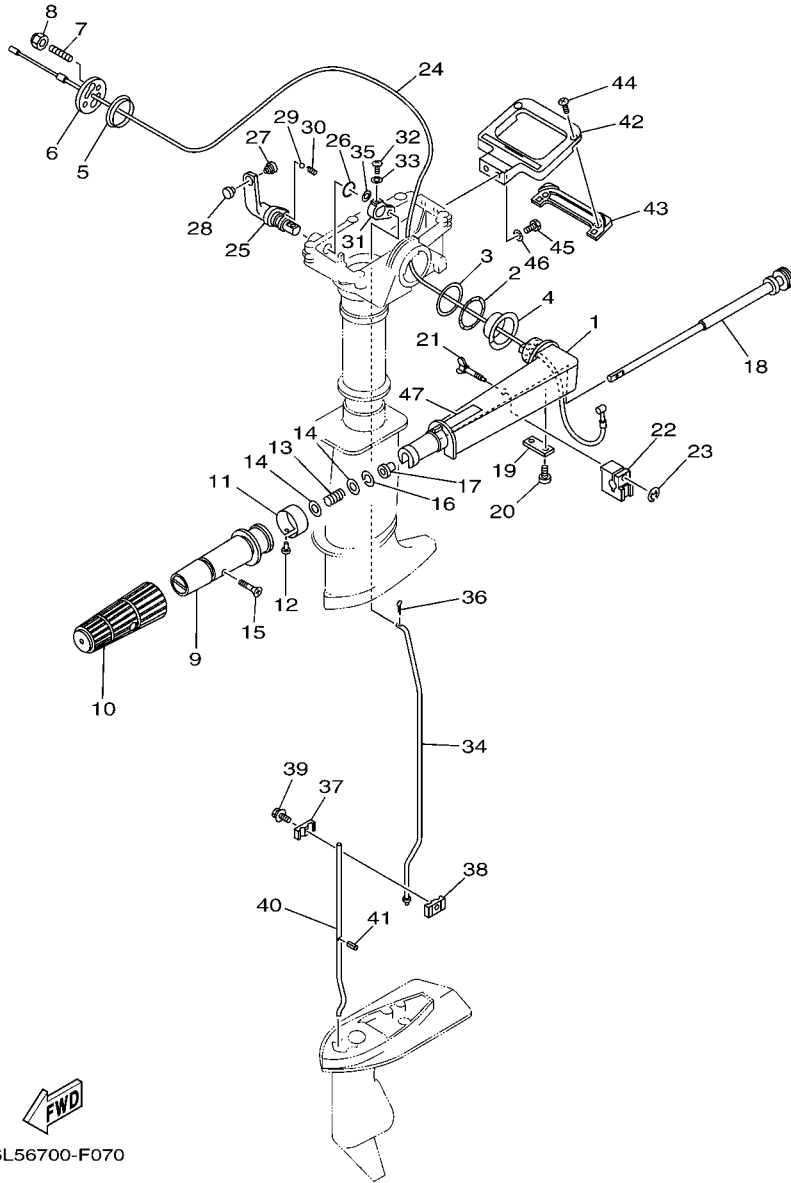

6L56700-F070

FIG. 7 CONTROL

REF. NO.	PART NO.	DESCRIPTION	6L56				REMARKS
1	6G1-42111-12-4D	HANDLE, STEERING	1				
2	90206-36M21	WASHER, WAVE	1				
3	90202-36M55	WASHER, PLATE	1				
4	90386-34M97	BUSH	1				
5	90386-33M96	BUSH	1				
6	6G1-42131-02	COVER, HANDLE STEERING	1				
7	90116-08016	BOLT, STUD	1				
8	90185-08057	NUT, SELF-LOCKING	1				
9	664-42119-00	GRIP, STEERING HANDLE	1				
10	6G1-42177-00	RUBBER, HANDLE	1				
11	6L5-42137-00	INDICATOR, THROTTLE	1				
12	90269-02M09	RIVET	1				
13	90501-23215	SPRING, COMPRESSION	1				
14	90201-10M02	WASHER, PLATE	2				
15	90149-05M13	SCREW	1				
16	90209-08M17	WASHER	1				
17	90386-08032	BUSH	1				
18	6G1-42138-01	LEVER, THROTTLE	1				
19	6E0-42159-02	STAY	1				
20	97885-05012	SCREW, PAN HEAD	2				
21	6L5-42125-00	BOLT, FRICTION ADJUSTING	1				
22	6G1-42126-00	FRICTION, STEERING HANDLE GRIP	1				
23	99080-03600	CIRCLIP	1				
24	6L5-26301-01	THROTTLE CABLE ASSY	1				
25	6L5-44111-00	HANDLE, GEAR SHIFT	1				
26	93210-12327	O-RING	1				
27	6L5-44196-00	INDICATOR 3	1				

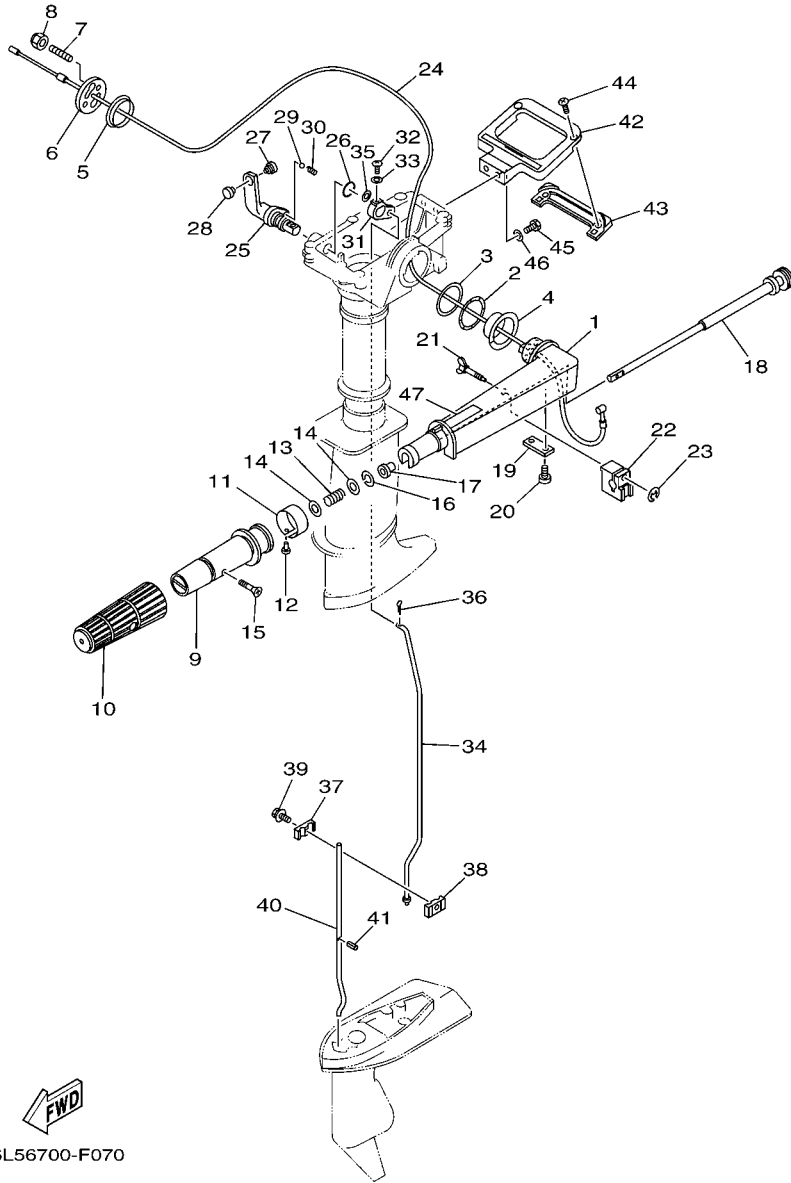

6L56700-F070

FIG. 7 CONTROL

REF. NO.	PART NO.	DESCRIPTION	6L56				REMARKS
28	6L5-44197-00	INDICATOR 4	1				
29	93505-16024	BALL	1				
30	90501-12274	SPRING, COMPRESSION	1				
31	6L5-44121-00	LEVER, SHIFT ROD	1				
32	97780-40520	SCREW, TAPPING	1				
33	92990-04600	WASHER, PLATE	1				
34	6L5-44143-00	ROD, SHIFT	1				
35	92990-05600	WASHER, PLATE	1				
36	91490-16010	PIN, COTTER	1				
37	6E0-44145-00	CONNECTOR, SHIFT ROD	1				
38	6E0-44146-00	CONNECTOR, SHIFT ROD	1				
39	95895-06020	BOLT, FLANGE	1				
40	6L5-44144-00	ROD, SHIFT	1				S(17.4")
41	91609-25014	PIN, SPRING	1				
42	6L5-42731-00-4D	CARRYING HANDLE	1				
43	6L5-42735-00	PROTECTOR	1				
44	90161-04M02	SCREW, TAPPING	2				
45	97095-06020	BOLT	2				
46	92995-06600	WASHER	2				
47	6A1-2415A-41	LABEL, CAUTION	1				

FIG. 8 UPPER CASING & BRACKET

REF. NO.	PART NO.	DESCRIPTION	6L56				REMARKS
1	6L5-45111-02-4D	CASING, UPPER	1				
2	93604-12M07	PIN, DOWEL	2				
3	97095-06030	BOLT	6				
4	92995-06600	WASHER	6				
5	93700-06M03	NIPPLE, GREASE	1				
6	6L5-45152-00	COVER, UPPER CASING 2	1				
7	6L5-45115-A0	GASKET, UPPER CASING	1				
8	90149-05M08	SCREW	1				
9	647-45151-01	COVER, UPPER CASING	1				
10	6L5-43111-01-4D	BRACKET, CLAMP 1	1				
11	6L5-43112-00-4D	BRACKET, CLAMP 2	1				
12	620-43114-00	PAD, TRANSOM CLAMP	2				
13	6E0-43116-01	SCREW, TRANSOM CLAMP	2				
14	6E0-43118-01	HANDLE, TRANSOM CLAMP	2				
15	90243-04M01	PIN	2				
16	90101-08M10	BOLT	1				
17	6G1-43136-00	PIECE, FRICTION	2				
18	6L5-42121-00	BRACKET	1				
19	90508-16M30	SPRING, TORSION	1				
20	90185-08057	NUT, SELF-LOCKING	1				
21	6A1-43113-01	PLATE, CLAMP BRACKET	1				
22	90387-06M11	COLLAR	1				
23	90101-06335	BOLT	1				
24	92990-06600	WASHER, PLATE	1				
25	95380-06600	NUT, HEXAGON	1				
26	6L5-43311-01-4D	BRACKET, SWIVEL 1	1				
27	6L5-44511-00-4D	COVER, UPPER MOUNT	1				

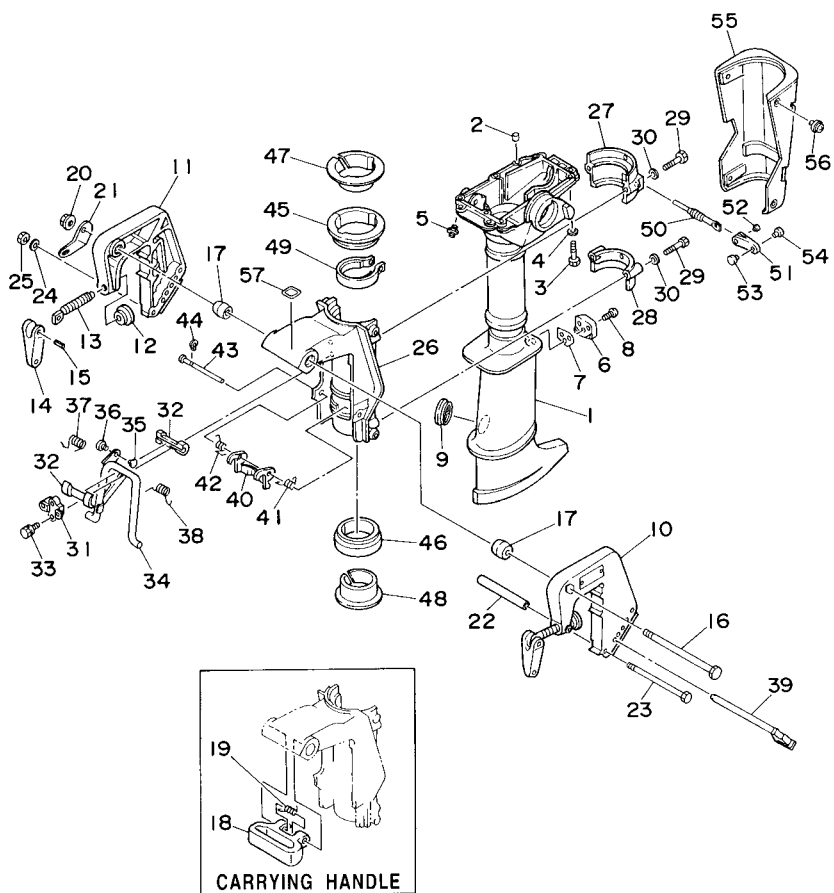

FWD
6L50100-4050

FIG. 8 UPPER CASING & BRACKET

REF. NO.	PART NO.	DESCRIPTION	6L56				REMARKS
28	6L5-44553-00-4D	COVER, LOWER MOUNT	1				
29	97095-06035	BOLT	4				
30	92995-06600	WASHER	4				
31	6E0-43313-00-94	BRACKET, SWIVEL 3	1				
32	620-43189-00	BUSHING	2				
33	95895-06020	BOLT, FLANGE	2				
34	6L5-43181-00	LEVER, TILT STOP	1				
35	6L5-44196-00	INDICATOR 3	1				
36	6L5-44197-00	INDICATOR 4	1				
37	90508-16020	SPRING, TORSION	1				
38	90508-16021	SPRING, TORSION	1				
39	6L5-43160-00	TILT ROD ASSY	1				
40	6L5-43614-00	PLATE, TILT LOCK	1				
41	90508-08M26	SPRING, TORSION	1				
42	90508-08M27	SPRING, TORSION	1				
43	6L5-43659-00	SHAFT, REVERSE LOCK	1				
44	99080-05600	CIRCLIP	1				
45	6L5-42537-00	BUSHING, PIVOT SHAFT	1				
46	6L5-42538-00	BUSHING, PIVOT SHAFT	1				
47	6L5-42539-00	BUSHING, PIVOT SHAFT	1				
48	6L5-42549-00	BUSHING, PIVOT SHAFT	1				
49	6E0-42528-03	PLATE, FRICTION	1				
50	6L5-42529-01	SCREW, FRICTION PIECE	1				
51	6L5-42561-00	KNOB, STEERING LOCK	1				
52	90266-04M05	RIVET	1				
53	6L5-44196-00	INDICATOR 3	1				
54	6L5-44197-00	INDICATOR 4	1				

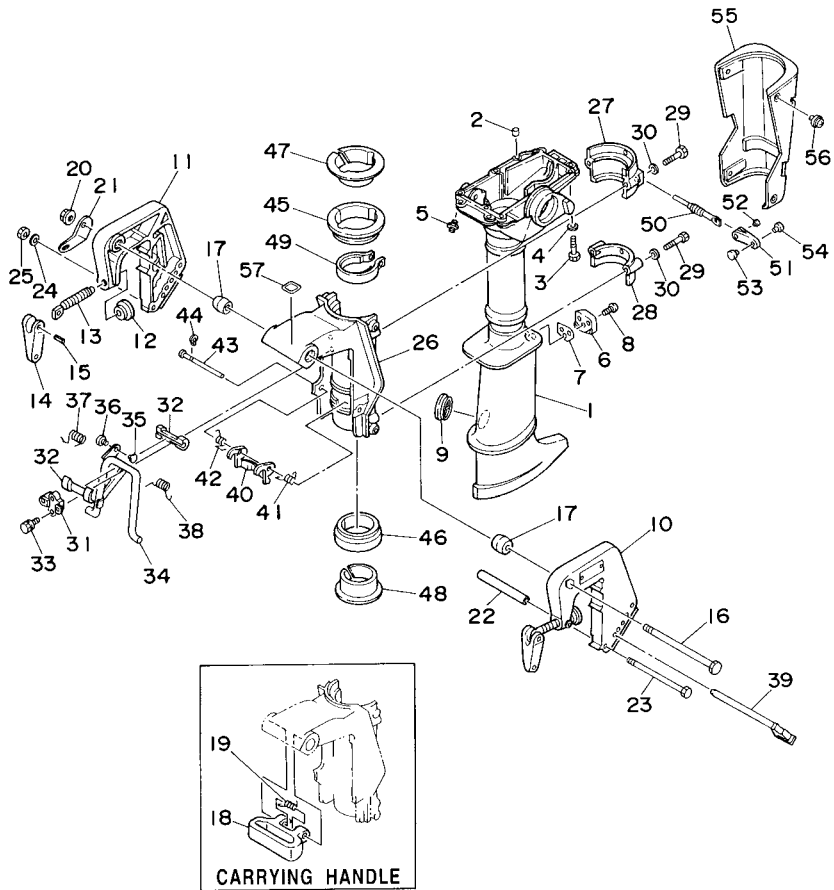

6L50100-4050

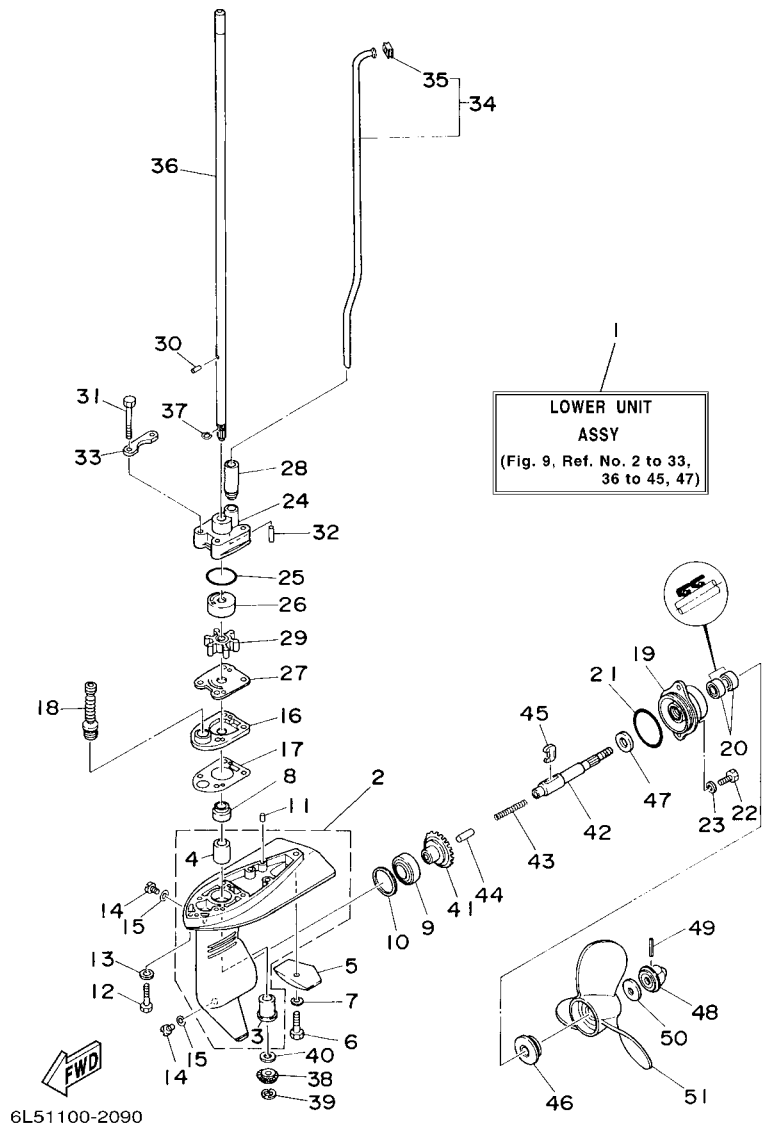

6L51100-2090

FIG. 9 LOWER CASING & DRIVE

REF. NO.	PART NO.	DESCRIPTION	6L56				REMARKS
1	6L5-45300-01-4D	LOWER UNIT ASSY	1				S(17.4")
2	6L5-45311-00-4D	CASING, LOWER	1				
3	6L5-45317-09	.BUSHING, DRIVE SHAFT	1				
4	6L5-45316-09	.BUSHING, DRIVE SHAFT	1				
5	6L5-45251-03	ANODE	1				
6	95895-06030	BOLT, FLANGE	1				S(17.4")
7	92990-06300	WASHER, INTERNAL TOOTH	1				
8	93103-09M41	OIL SEAL	1				
9	93316-003U0	BEARING	1				
10	6L5-45567-00	SHIM	1				UN
11	93604-12M07	PIN, DOWEL	2				
12	97095-06030	BOLT	3				S(17.4")
13	92995-06600	WASHER	3				S(17.4")
14	90340-08002	PLUG, STRAIGHT SCREW	2				
15	90430-08020	GASKET	2				
16	6L5-45321-00-5B	PLATE	1				
17	6L5-45315-A0	PACKING, LOWER CASING	1				
18	6L2-44147-00	BOOT, SHIFT ROD	1				
19	6L5-45361-00-4D	CAP, LOWER CASING	1				
20	93101-13M12	OIL SEAL	2				
21	93210-48214	O-RING	1				
22	97095-06016	BOLT	2				
23	92995-06600	WASHER	2				
24	6L5-44311-00	HOUSING, WATER PUMP	1				
25	93210-33M85	O-RING	1				
26	6L5-44322-00	INSERT, CARTRIDGE	1				
27	6L5-44323-00	OUTER PLATE, CARTRIDGE	1				

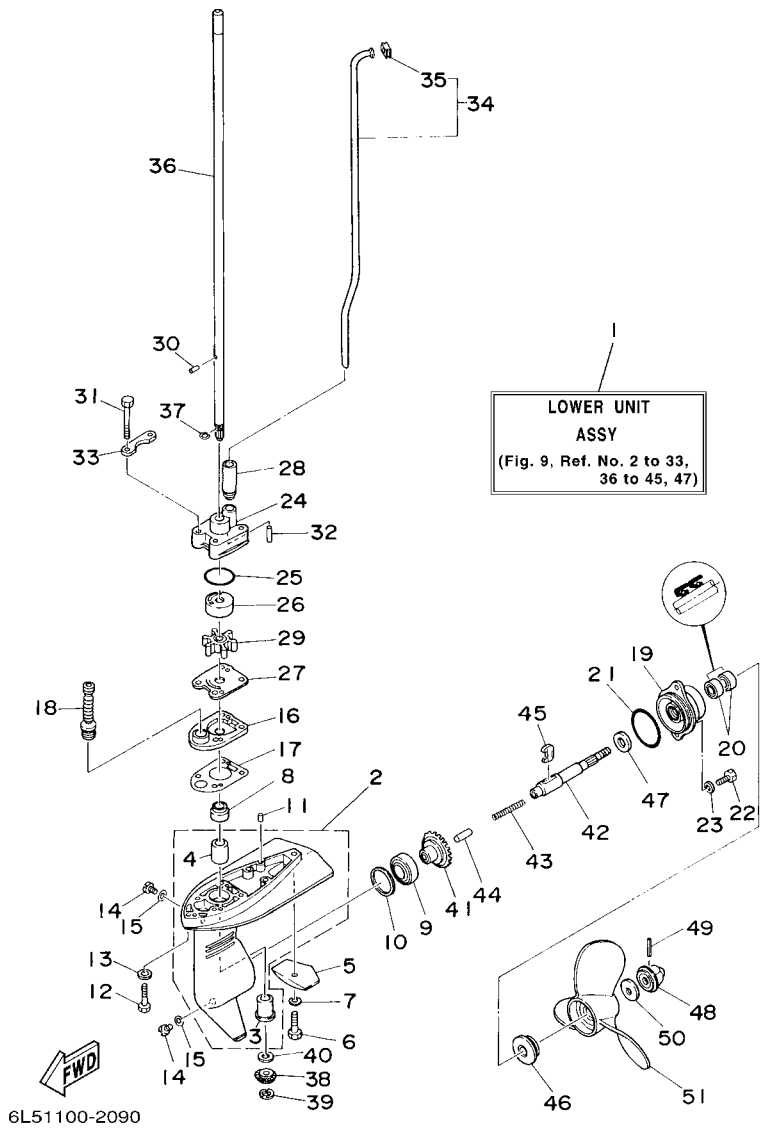

6L51100-2090

FIG. 9 LOWER CASING & DRIVE

REF. NO.	PART NO.	DESCRIPTION	6L56				REMARKS
28	6E0-44366-00	DAMPER, WATER SEAL	1				
29	6L5-44352-00	IMPELLER	1				
30	93604-07M13	PIN, DOWEL	1				
31	97095-06040	BOLT	4				
32	93604-18080	PIN, DOWEL	2				
33	6L5-44328-00	PLATE	2				
34	6L5-44360-01	WATER TUBE ASSY	1				S(17.4")
35	646-44365-00	.DAMPER, WATER SEAL	1				
36	6L5-45511-00	SHAFT, DRIVE	1				S(17.4")
37	90467-07M12	CLIP	1				
38	6L5-45551-00	PINION (13T)	1				
39	99001-06600	CIRCLIP	1				
40	6L5-45533-00	SHIM (T:2.0MM)	1				UR
	6L5-45533-10	SHIM (T:2.1MM)	1				UR
	6L5-45533-20	SHIM (T:2.2MM)	1				UR
	6L5-45533-30	SHIM (T:2.3MM)	1				UR
41	6L5-45560-00	GEAR 1 (27T)	1				
42	6L5-45611-00	SHAFT, PROPELLER	1				
43	90501-10064	SPRING, COMPRESSION	1				
44	6L5-45635-00	PLUNGER, SHIFT	1				
45	6L5-45631-00	CLUTCH, DOG	1				
46	6L5-45987-01	SPACER	1				
47	90201-13198	WASHER, PLATE	1				
48	6L5-45616-00	NUT, PROPELLER	1				
49	91490-25030	PIN, COTTER	1				
50	90201-08M54	WASHER, PLATE	1				
51	6L5-45943-00-EL	PROPELLER (3X7-1/4"X6"-BS)	1				UR

FIG. 10 REPAIR KIT

REF. NO.	PART NO.	DESCRIPTION	6L56				REMARKS
1	6L5-W0001-A1	POWER HEAD GASKET KIT	1				
2	93101-20M29	.OIL SEAL	1				
3	93101-09M42	.OIL SEAL	1				
4	6L5-15369-A0	.GASKET, OIL SEAL HOUSING	1				
5	6L5-11181-A2	.GASKET, CYLINDER HEAD 1	1				
6	6L5-11193-A1	.GASKET, HEAD COVER 1	1				
7	6L5-12414-A1	.GASKET, COVER	1				
8	93102-20M06	.OIL SEAL	1				
9	6L5-13621-A2	.GASKET, VALVE SEAT	1				
10	6L5-14198-A1	.GASKET	1				
11	6G1-14398-00	.WASHER	1				
12	6L5-45113-A1	.GASKET, UPPER CASING	1				
13	646-44365-00	.DAMPER, WATER SEAL	1				
14	6G1-W0093-00	CARBURETOR REPAIR KIT	1				
15	679-14923-00	.SCREW, PILOT	1				
16	6G1-14966-00	.CAP	1				
17	6G1-14126-00	.GASKET	1				
18	676-14966-00	.CAP	1				
19	6G1-14984-00	.O-RING	1				
20	97980-04114	.SCREW, WITH WASHER	4				
21	6G1-14985-00	.FLOAT	1				
22	6G1-14546-00	.VALVE, NEEDLE	1				
23	676-14186-00	.PIN, FLOAT	1				
24	688-14548-00	.PIN, FLOAT ARM	1				
25	6L5-W0001-21	LOWER UNIT GASKET KIT	1				
26	93103-09M41	.OIL SEAL	1				
27	90430-08020	.GASKET	2				

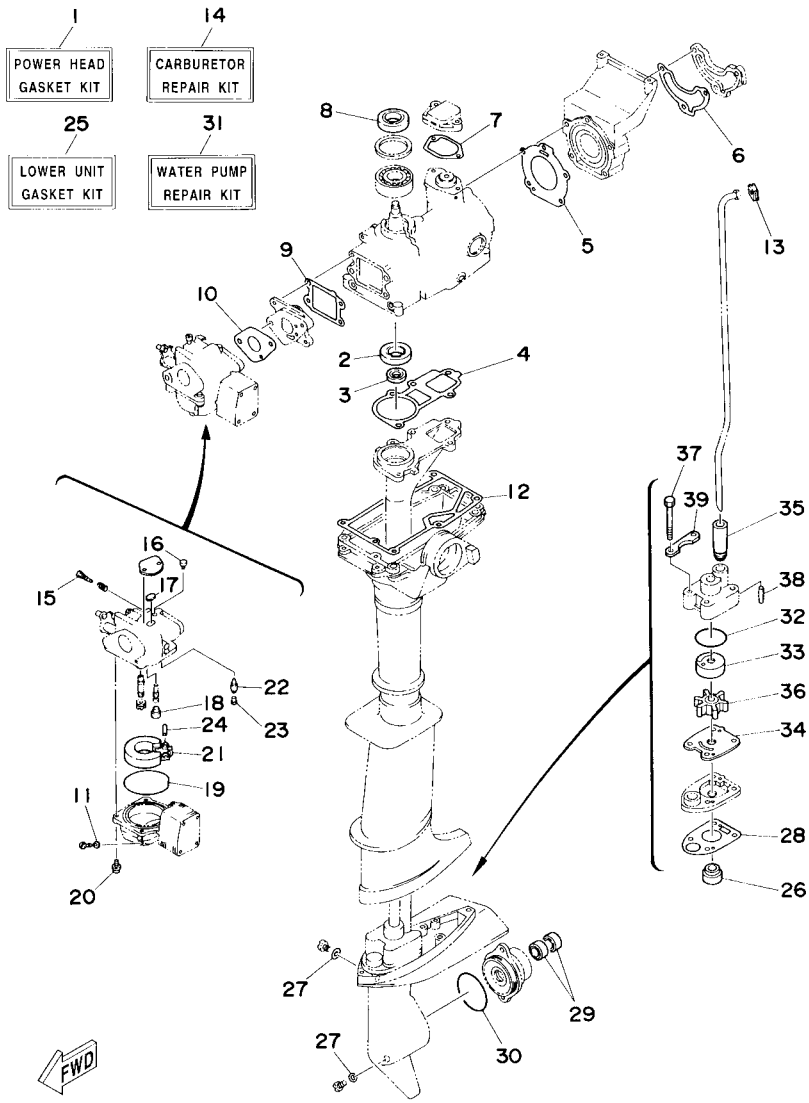

6L50010-4100

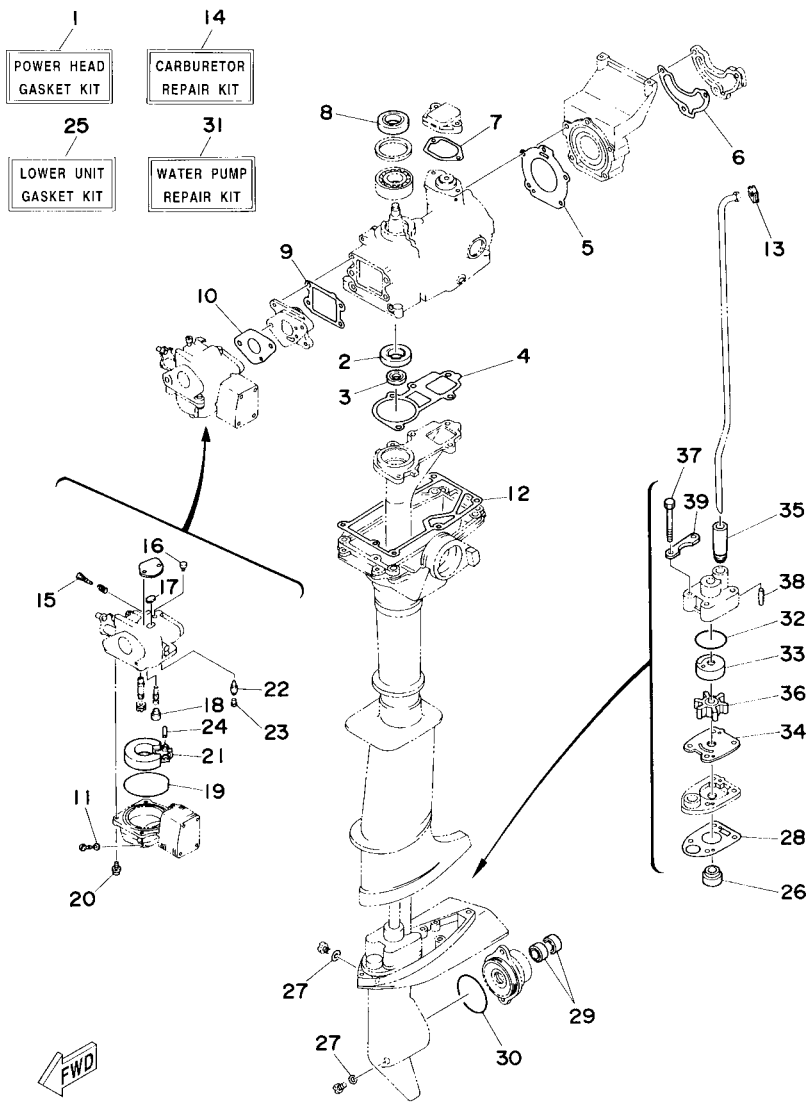

FIG. 10 REPAIR KIT

REF. NO.	PART NO.	DESCRIPTION	6L56				REMARKS
28	6L5-45315-A0	.PACKING, LOWER CASING	1				
29	93101-13M12	.OIL SEAL	2				
30	93210-48214	.O-RING	1				
31	6L5-W0078-00	WATER PUMP REPAIR KIT	1				
32	93210-33M85	.O-RING	1				
33	6L5-44322-00	.INSERT, CARTRIDGE	1				
34	6L5-44323-00	.OUTER PLATE, CARTRIDGE	1				
35	6E0-44366-00	.DAMPER, WATER SEAL	1				
36	6L5-44352-00	.IMPELLER	1				
37	97095-06040	.BOLT	4				
38	93604-18080	.PIN, DOWEL	2				
39	6L5-44328-00	.PLATE	2				

6L50010-4100

NUMERICAL INDEX

PART NO.	REF. NO.	PART NO.	REF. NO.	PART NO.	REF. NO.	PART NO.	REF. NO.	PART NO.	REF. NO.	PART NO.	REF. NO.
6L5-11111-00-1S	2 - 16	676-14943-14	3 - 20	61H-2819R-31	1 - 32	6E0-43313-00-94	8 - 31	6L5-45321-00-5B	9 - 16	90119-06047	2 - 18
6L5-11181-A2	2 - 17	676-14947-01	3 - 19	6L5-41252-00	3 - 45	6L5-43318-11	8 - 55	6L5-45361-00-4D	9 - 19	90119-06M65	1 - 21
	10 - 5	6L5-14948-03	3 - 11	6L5-41271-00	3 - 44	6L5-43614-00	8 - 40	6L5-45511-00	9 - 36	90119-06MA2	2 - 21
6L5-11191-00-1S	2 - 19	676-14966-00	3 - 12	689-41273-00	3 - 47	6L5-43659-00	8 - 43	6L5-45533-00	9 - 40		2 - 27
6L5-11193-A1	2 - 20		10 - 18	6J8-41274-00	3 - 48	6L5-44111-00	7 - 25	6L5-45533-10	9 - 40	90149-05M08	8 - 8
	10 - 6	6G1-14966-00	3 - 8	6G1-42111-12-4D	7 - 1	6L5-44121-00	7 - 31	6L5-45533-20	9 - 40	90149-05M13	7 - 15
6E5-11372-01	2 - 4		10 - 16	664-42119-00	7 - 9	6L5-44143-00	7 - 34	6L5-45533-30	9 - 40	90159-04035	5 - 11
6L5-11400-00	2 - 28	6G1-14980-01	3 - 18	6L5-42121-00	8 - 18	6L5-44144-00	7 - 40	6L5-45551-00	9 - 38	90159-04036	5 - 10
6L5-11412-00	2 - 29	6G1-14984-00	3 - 17	6L5-42125-00	7 - 21	6E0-44145-00	7 - 37	6L5-45560-00	9 - 41	90159-05037	5 - 9
6L5-11422-00	2 - 30		10 - 19	6G1-42126-00	7 - 22	6E0-44146-00	7 - 38	6L5-45567-00	9 - 10	90159-05038	5 - 8
6L5-11610-00	2 - 39	6G1-14985-00	3 - 24	6G1-42131-Q2	7 - 6	6L2-44147-00	9 - 18	6L5-45611-00	9 - 42	90159-06M10	1 - 24
6L5-11610-10	2 - 39		10 - 21	6L5-42137-00	7 - 11	6L5-44196-00	1 - 25	6L5-45616-00	9 - 48		8 - 56
6L5-11610-20	2 - 39	6G1-14992-00	3 - 23	6G1-42138-01	7 - 18		7 - 27	6L5-45631-00	9 - 45	90161-04M02	7 - 44
6L5-11631-00-96	2 - 38	6L5-15100-01-1S	2 - 2	6E0-42159-02	7 - 19		8 - 35	6L5-45635-00	9 - 44	90167-03M02	1 - 13
6L5-11633-00	2 - 41	6L5-15369-A0	2 - 13	6G1-42177-00	7 - 10		8 - 53	6L5-45943-00-EL	9 - 51	90170-10113	5 - 18
6L5-11635-00	2 - 38		10 - 4	6E0-42528-03	8 - 49	6L5-44197-00	1 - 26	6L5-45945-00-EL	9 - 51	90185-08057	7 - 8
6L5-11636-00	2 - 38	6L5-15396-00-94	2 - 10	6L5-42529-01	8 - 50		7 - 28	6L5-45947-00-EL	9 - 51		8 - 20
6L5-11651-00	2 - 31	6A1-15705-00	4 - 8	6L5-42537-00	8 - 45		8 - 36	6L5-45949-00-EL	9 - 51	90201-08M54	9 - 50
6L5-11681-00	2 - 32	6L5-15710-00	4 - 1	6L5-42538-00	8 - 46		8 - 54	6L5-45952-00-EL	9 - 51	90201-10126	5 - 19
6E5-12411-02	2 - 23	6L5-15711-00	4 - 2	6L5-42539-00	8 - 47	6L5-44311-00	9 - 24	6L5-45987-01	9 - 46	90201-10M02	7 - 14
6E5-12412-00	2 - 24	6L5-15713-00	4 - 6	6L5-42549-00	8 - 48	6L5-44322-00	9 - 26	6E0-81328-70	5 - 7	90201-13198	9 - 47
6L5-12413-00-1S	2 - 25	6L5-15714-00	4 - 4	6L5-42561-00	8 - 51		10 - 33	6E0-81336-70	5 - 6	90201-32M00	2 - 36
6L5-12414-A1	2 - 26	6L5-15716-00	4 - 7	6L5-42610-13-4D	1 - 1	6L5-44323-00	9 - 27	6L5-82316-00	6 - 2	90201-32M01	2 - 37
	10 - 7	6L5-15741-00	4 - 5	6L5-42647-00	1 - 11		10 - 34	6A0-82317-00	1 - 19	90202-36M55	7 - 3
6L5-13610-02	3 - 1	6L5-15755-00	4 - 18	6L5-42662-00	1 - 15	6L5-44328-00	9 - 33	6G1-82370-21	6 - 1	90206-36M21	7 - 2
6L5-13621-A2	3 - 3	6L5-15758-00-98	4 - 14	6L5-42663-00	1 - 16		10 - 39	6L5-82550-00	6 - 12	90209-08M17	7 - 16
	10 - 9	6L5-15761-00	4 - 16	6L5-42677-10	4 - 17	6L5-44352-00	9 - 29	6A1-83625-41	4 - 22	90243-04M01	8 - 15
6G1-14126-00	3 - 10	6A1-15767-00	4 - 10	6L5-42678-12	1 - 3		10 - 36	6E0-85520-70	5 - 3	90266-04M05	8 - 52
	10 - 17	6L5-15771-01-94	5 - 12	6L5-42711-11	1 - 4	6L5-44360-01	9 - 34	6L5-85540-M0	6 - 8	90269-02M09	7 - 12
663-14159-00	3 - 27	6L5-15779-00	4 - 19	6L5-42712-12	1 - 5	646-44365-00	9 - 35	6L5-85550-M1	5 - 1	90280-04M06	5 - 17
676-14186-00	3 - 26	6L5-15789-00	4 - 20	6L5-42731-00-4D	7 - 42		10 - 13	6L5-85560-M1	5 - 2	90340-08002	9 - 14
	10 - 23	6L5-24111-02	1 - 17	6L5-42735-00	7 - 43	6E0-44366-00	9 - 28	6L5-85570-N0	6 - 5	90386-08032	7 - 17
6L5-14198-A1	3 - 40	6A1-2415A-41	7 - 47	6L5-42774-00	1 - 6		10 - 35	6L5-85592-M0	5 - 5	90386-33M96	7 - 5
	10 - 10	6L5-24251-00	1 - 27	6L5-42775-00	1 - 7	6L5-44511-00-4D	8 - 27	6L5-85595-M0	5 - 4	90386-34M97	7 - 4
6L5-14301-03	3 - 5	6L5-24311-00	1 - 28	6H8-42791-10	4 - 21	6L5-44553-00-4D	8 - 28	6L5-W0001-21	10 - 25	90387-06119	1 - 20
6G1-14398-00	3 - 22	6L5-24312-00	1 - 30	6A1-42792-01	8 - 57	6L5-45111-02-4D	8 - 1	6L5-W0001-A1	10 - 1	90387-06M11	8 - 22
	10 - 11	6G1-24411-00	3 - 37	6L5-42823-00	1 - 12	6L5-45113-A1	2 - 43	6L5-W0004-02	3 - 2	90387-06M70	4 - 3
6L5-14440-00	3 - 41	6G1-24412-01	3 - 36	6L5-43111-01-4D	8 - 10		10 - 12	6L5-W0070-13	1 - 2	90430-08020	9 - 15
624-14485-00	2 - 3	6L5-24421-00	3 - 39	6L5-43112-00-4D	8 - 11	6L5-45115-A0	8 - 7	6L5-W0078-00	10 - 31		10 - 27
63V-14523-00	3 - 16	6G1-24431-01	3 - 38	6A1-43113-01	8 - 21	647-45151-01	8 - 9	6L5-W0090-01-1S	2 - 1	90445-07M29	2 - 5
6G1-14527-00	3 - 9	6G1-24432-00	3 - 34	620-43114-00	8 - 12	6L5-45152-00	8 - 6	6G1-W0093-00	10 - 14	90446-10M01	5 - 13
6G1-14546-00	3 - 25	6L5-24452-00	3 - 33	6E0-43116-01	8 - 13	6L5-45251-03	9 - 5	656-W2810-02	1 - 33	90465-10M34	5 - 15
	10 - 22	6G1-24471-00	3 - 35	6E0-43118-01	8 - 14	6L5-45300-01-4D	9 - 1	90101-06335	8 - 23	90465-13M11	1 - 31
688-14548-00	3 - 29	6L5-24500-60	1 - 23	6G1-43136-00	8 - 17	6L5-45311-00-4D	9 - 2	90101-08M10	8 - 16	90465-18147	6 - 11
	10 - 24	6L5-24591-00	1 - 14	6L5-43160-00	8 - 39	6L5-45315-A0	9 - 17	90105-06M16	2 - 8	90467-06016	2 - 6
679-14555-00	3 - 7	6L5-24610-00	1 - 18	6L5-43181-00	8 - 34		10 - 28	90105-06M40	2 - 9	90467-07M12	9 - 37
679-14923-00	3 - 6	6L5-24641-00	1 - 22	620-43189-00	8 - 32	6L5-45316-09	9 - 4	90116-08016	7 - 7	90467-08004	1 - 29
	10 - 15	6L5-26301-01	7 - 24	6L5-43311-01-4D	8 - 26	6L5-45317-09	9 - 3	90119-06027	2 - 22	90501-10064	9 - 43

NUMERICAL INDEX

PART NO.	REF. NO.	PART NO.	REF. NO.	PART NO.	REF. NO.	PART NO.	REF. NO.	PART NO.	REF. NO.	PART NO.	REF. NO.
90501-10326	3 - 15	93505-16024	7 - 29								
90501-12274	7 - 30	93604-07M13	9 - 30								
90501-23215	7 - 13	93604-12M07	8 - 2								
90508-08M26	8 - 41		9 - 11								
90508-08M27	8 - 42	93604-18080	9 - 32								
90508-16020	8 - 37		10 - 38								
90508-16021	8 - 38	93606-12019	2 - 7								
90508-16M30	8 - 19	93700-06M03	8 - 5								
91490-16010	7 - 36	94702-00274	2 - 44								
91490-25030	9 - 49	95380-03600	3 - 31								
91609-25014	7 - 41	95380-06600	8 - 25								
91690-40048	3 - 46	95895-06016	3 - 4								
92990-04100	3 - 14		4 - 15								
92990-04600	7 - 33		5 - 16								
92990-05600	7 - 35	95895-06020	4 - 12								
92990-06300	9 - 7		7 - 39								
92990-06600	6 - 7		8 - 33								
	6 - 14	95895-06030	9 - 6								
	8 - 24	95895-06035	4 - 13								
92995-06600	1 - 10	95895-06095	3 - 43								
	2 - 15	97090-06012	6 - 13								
	6 - 4	97095-06016	1 - 9								
	6 - 10		6 - 3								
	7 - 46		6 - 9								
	8 - 4		9 - 22								
	8 - 30	97095-06020	2 - 14								
	9 - 13		7 - 45								
	9 - 23	97095-06030	8 - 3								
93101-09M42	2 - 12		9 - 12								
	10 - 3	97095-06035	8 - 29								
93101-13M12	9 - 20	97095-06040	9 - 31								
	10 - 29		10 - 37								
93101-20M29	2 - 11	97313-06012	4 - 9								
	10 - 2	97780-40520	7 - 32								
93102-20M06	2 - 35	97780-40716	3 - 42								
	10 - 8	97803-05008	5 - 14								
93103-09M41	9 - 8	97880-04010	3 - 13								
	10 - 26	97880-05010	1 - 8								
93210-12327	7 - 26	97880-06016	6 - 6								
93210-33M85	9 - 25	97885-05012	7 - 20								
	10 - 32	97980-04114	3 - 21								
93210-48214	9 - 21		10 - 20								
	10 - 30	97980-04125	3 - 32								
93306-204U0	2 - 34	98580-04008	3 - 28								
93310-112U0	2 - 40	98980-03006	3 - 30								
93310-416N7	2 - 33	99001-06600	9 - 39								
93316-003U0	9 - 9	99080-03600	7 - 23								
93450-13022	2 - 42	99080-05600	8 - 44								